

- Unique Installation Concept
- Anti-Tamper Facility
- Enhanced Aesthetics
- Fully Approved to the Latest Standards
- Integral Short Circuit Isolator
- Re-settable Break Glass Element
- Backward Compatibility



6000/MCP Manual Call Point - Installation efficiency, flexibility and full compliance with the latest standards are at the heart of the 6000/MCP indoor call point.

Installation time and ultimately cost, are of paramount importance to any fire or security installer.

The 6000/MCP range directly reflects this need by providing a simple connection concept designed specifically to reduce installation time.

The 6000/MCP utilises a special terminal block, where all initial installation cabling is terminated. This terminal block is then simply connected to the back of the 6000/MCP. Simple, but effective, with no re-termination required and no time wasted.

The 6000/MCP indoor call point also helps to preserve the integrity of the overall system, as illegal removal of the product lid will result in the call point operating and the system going into alarm.

Full compliance with the latest standards is essential and the 6000/MCP indoor call point is fully approved to the latest EN54 Part 11 standard.

Order Codes

6000/MCP	(UK Model)
6000/MCP/NL	(Dutch Model)
6000/MCP/EXP	(Export Model)

6000/MCP Technical Specification



LPCB ref. no. 201ae

Dimensions

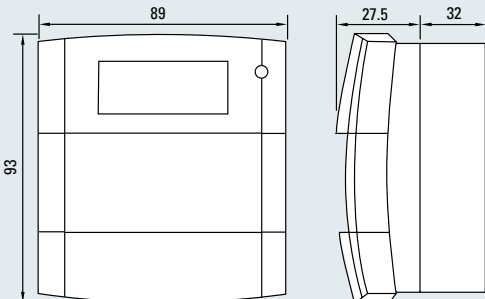

Typical Wiring

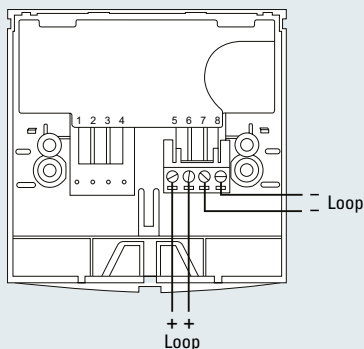

Technical Specification:

Environment	-10°C to +55°C
Humidity	0-95% non condensing
IP Rating	IP24D
Weight	Flush - 93g, Surface - 144g
Operating Voltage	16 - 30V DC
Loop Powered	Yes
Loop Standby Load	450µA
Loop Alarm Load	0.85mA
LED Illuminated	4.5mA
Device Protocol	Algo-Tec™ 6000
Product Approval	LPCB Certificate No: 201ae EC Certificate No: 0832-CPD-1049 DoP No: PFD-CPR-0018 (UK Model) PFD-CPR-0019 (Dutch Model) PFD-CPR-0020 (Export Model) Relevant Standard: EN 54-11 & 17 and AS7240 Part 11 (Export Model only)



Company Policy is one of continuous improvement, we reserve the right to change specification without prior notice

Protec Fire Detection Plc, Protec House, Churchill Way, Nelson, Lancashire, BB9 6RT

© 2010 - 2016 Protec Fire Detection plc

Tel: 01282 717171 Fax: 01282 717273 Web: www.protec.co.uk Email: sales@protec.co.uk